

Adjustable Support Bridge

ASB3624

Description:

KeyCurb Bridge: Molded recycled rubber curb with galvanized channel.
 Channel Leg, Adjustable Cross Bar: pre-galvanized 1 5/8" channel.
 Adjustable System. (No pads or slip sheet required.)
 All parts and accessories can be ordered separately.

Installation:

Base and support framing shall be located as specified or required herein as per drawings.
 Frame spacing shall be as indicated on drawings, but not to exceed 10' centers.
 Bases shall be placed on completed roofing as per manufacturer's requirements.
 Set 1 5/8" channel leg into base bracket. Bolt with washer and nut.
 Add top frame and bolt to support legs.
 Install required pipe hanger.
 Adjust each hanger to its desired height. Check each support for equal weight disbursement.

Assembly Components

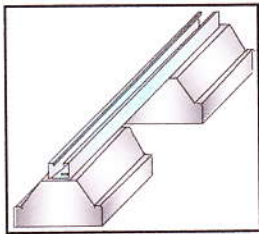

Item No.	Size
SH02	(2")
SH04	(4")
SH06	(6")
SH08	(8")

Swivel Hangers

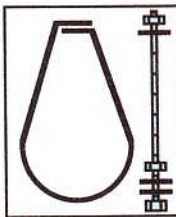

Clevis Hangers

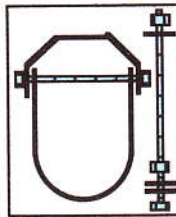

KeyCurb Bridge

Item No.	Strut	Curb
KCB	24"-36"-48"	(9")

Item No.	Size
CH02	(2")
CH04	(4")
CH06	(6")
CH08	(8")
CH10	(10")
CH12	(12")

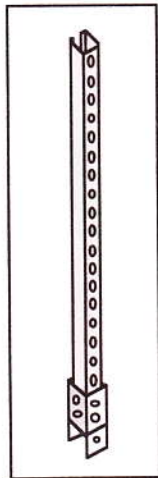
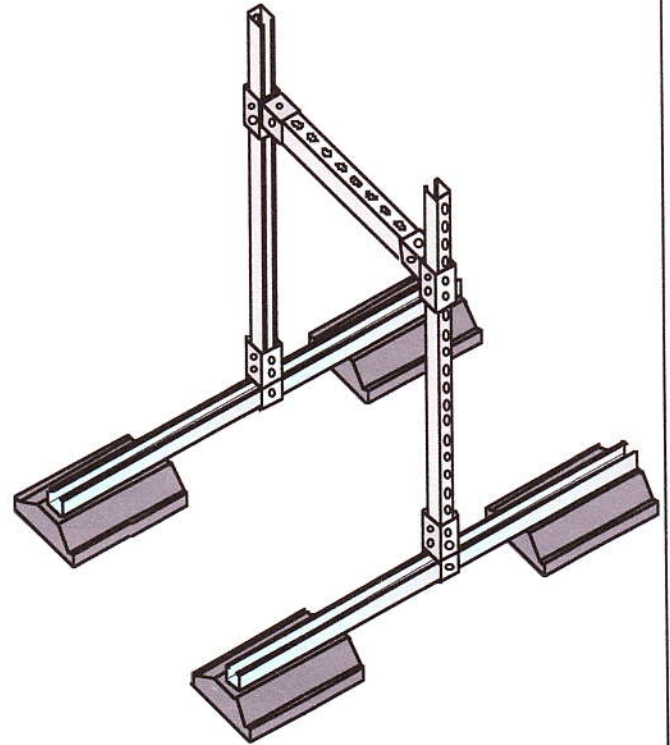

Channel Leg

Item No.	Size
CL18	(18")
CL24	(24")
CL36	(36")
CL48	(48")
CL60	(60")

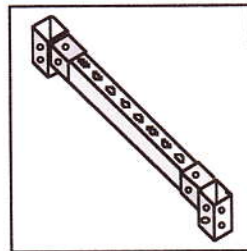

Adjustable Cross Bar

Item No.	Size
ACB18	(18")
ACB24	(24")
ACB36	(36")
ACB48	(48")



KeyCurb Pipe Supports